

Fault Detection System in Transmission Line Network

Gupta Ankita* and Potdar R. M
ET and T Department, BIT, Durg, India

Available online at: www.isca.in, www.isca.me

Received 24th February 2016, revised 20th April 2016, accepted 23rd May 2016

Abstract

Now a days, technology has advanced and its incorporation is playing such a significant role in human life that the order of the electricity power for the household, commercial and industrial loads is getting enhanced. Also, managing the electricity power distribution system is getting more complex. Thus, examining such kind of faults is an imperative and complicated charge in power system. For accurate detection and study of these faults, there is a requirement of model that detects this faults and its distance in transmission line. The statistical model precisely detains the performance of such unusual faults and position in suitable mode, and prevents power system from faulty energy. The faults which occur in transmission lines can cause interruptions of power supplied. We can develop an outline in this concern to have an in built intelligence to sense the incidence of error in the transmission line. So, to make sure a secured operation of distribution and decrease the losses occurred by accidents, a far-off monitoring and controlling system is developed. This paper proposes Fault Detection, Classification and auto retrieve from the fault in Power Transmission Lines based on MATLAB with Arduino 328 hardware which helps in greatly reducing the human effort, minimizes times and works safely and proficiently without the interference of human being.

Keywords: Fault location, Arduino 328, Adaptive technique, Transmission lines.

Introduction

In past few years, power distribution system has turned into more vigorously in this deregulated environment. And thus now we require more superior tenable control to get desirable operation. As per demand, the security of power distributed is the major concern in today's life. Therefore, to have a secured power transmission, fault detection is the foremost important task to be accomplished¹. Specially, it stipulates that power distribution system must operate at control centers accurately handles in sequence on faults and detects it correctly or in other words we can say that more refined fault recognition technique are necessary to maintain secure and safe power system². In this regard many approaches have been proposed based on neural network approach⁴ and Fuzzy approach to fault classification for transmission line protection⁵. The paper presented now is a new approach for fault detection and its classification. Here, an auto retrieve from the fault in Power Transmission Lines based on MATLAB with Arduino 328 hardware which helps in reducing human effort, lessen times to find type of fault and works safely and capably without the interference of human being.

When in transmission line applying multiple numbers of loads, then a conditional monitoring is performed by the microcontroller (Arduino 328), If any imbalance in amplitude of supplied voltage is noticed then as per the programming an immediate action is taken by the Arduino 328 and appropriate trip signal is applied to the relay circuitry. Also, displaying the type of fault in the computer screen.

Losses caused in transmission lines

If a power plant generates 150 MWH, on an average only 95 MWH of that energy is distributed and transmitted in the system. On an average, Line loss= 1 to 2 percent for EHV Transmission and 2 to 4 percent overall lines and substations. On an average. Line loss=4 to 6 percent for distribution losses. These losses at their maximum power are higher and can go up to 10 to 15 percent because of higher resistance and reactance consumed. According to Joules Law, it states that the energy loss is straightly relative to the square of the current that is; the more the voltage will decrease the current and thus decreases the virtual losses. Hence, the line losses are dissipated in form of heat, hot conductor sag, for such reason transmission lines have a kind of thermal constrains.

Different forms of faults

In general, basically two kinds of faults occur in any transmission line network which is unbalanced and balanced faults also known as symmetric and asymmetric faults resp. We see that maximum no. of faults which is encountered is of unbalanced type in any power distribution system. Adding up, faults can also be viewed as series and shunt faults.

The series fault are those type of faults which occurs in impedance of the line and it doesn't engage any ground and neutral nor any interconnection between the phases. Here, we find an increased level of frequency and voltage and drop off of current in the distorted phases, such as if there occurs any one or two opening of lines by the circuit breaker. And, the shunt one

is the unbalanced between any phases or any phase and ground. Different types of faults can be viewed in following forms as shown in Figures-1,2,3 and 4: Single line to ground faults, Double line to ground faults, Line to line faults and, Three phase faults.

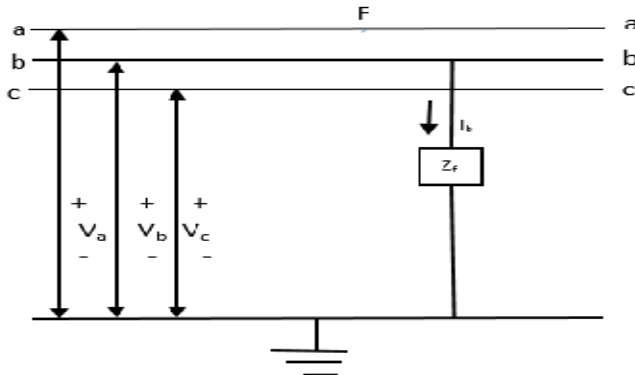

Figure-1
 Single line to ground (LG) fault

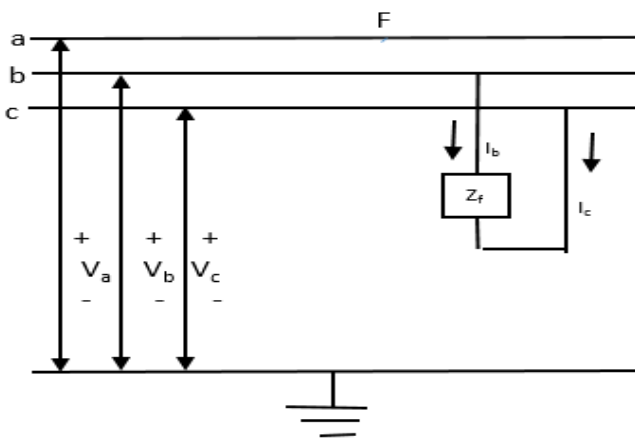

Figure-2
 Line to line (LL) fault

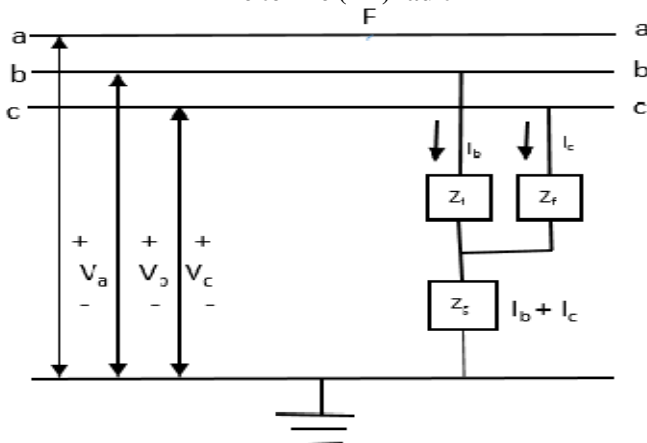

Figure-3
 Double line to ground (LLG) fault

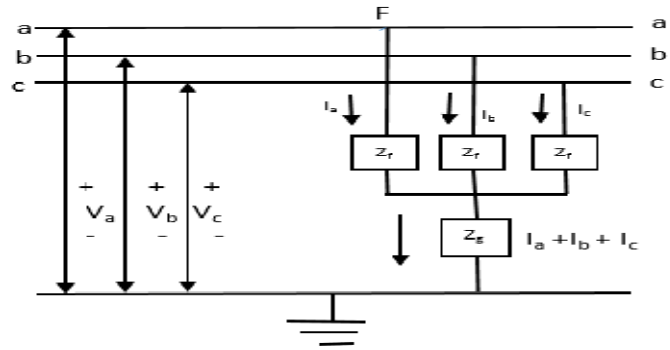

Figure-4
 Three phase (LLLG) fault

Functional block diagram of fault detection system

The Figure-5 represents the block diagram for accurate fault detection, classification and takes up again the correct pattern upon analysis. Here, a 230V AC supply is required to operate the system. 12V AC supply is fed to the relay connected to sense the presence of any misbehavior phase and thus to isolate it from the rest of the circuitry. Microcontroller circuit is energized by feeding a +5 V supply and its ports are assigned their respective function. Different types of faults are considered. The voltage passing through the line is monitored, if there occurs any imbalance in supplied signal then, immediately the controller will starts its timer. If the fault persist for more than predefined value then a auto retrieving to normal stage is carried out also the type of fault and when it has occurred will be recorded in the computer screen. Among the most important components required to accomplish this task few of them are as follows in Figure-5.

Power Transformer 230V/12V, 3 amps the Relay (12V, 10amp), Contactor (230 V, 10 amp), Push buttons, Arduino 328.

Power Transformer: Power transformer is a device made to step up or step down the alternating voltages. Basically, two types of power transformer are in hand which is step up and step down transformers. As per the number of turns in the primary and secondary winding of the transformer, one can increase or decrease the amplitude of supplied voltage. For this project work we are considering six steps down power transformer of rating 230 V/12V to represent a realistic representation of the three phase system.

Arduino 328: The Arduino Uno in Figure-6 shows a microcontroller derived from ATmega 328. It consists of 14 digital i/o pins. Among this i/o pins, six are used as pulsed width modulated output other six as analog inputs, a USB connection, a 16MHZ resonator of ceramic type, a reset button, an ICSP header and a power jack. It has most of the things inbuilt that is needed to uphold the microcontroller; we merely

have to make connection with the computer with the help of USB cable or power it with battery or any AC /DC adapter. The latest among the series is the UNO Arduino board. The Uno is the latest in a series of USB Arduino boards. The Arduino Uno and its version 1.0 is taken as reference version for further moving ahead's.

Expected result

The simulated data of voltage and current phases is fed to a MATLAB based programming to detect the fault in transmission line. The waveforms of voltage and current at the terminals are obtained from Simulink model during single phase

to ground (L-G) fault is shown in Figure-7. Similarly, the voltages and currents waveforms at other terminal for other types of faults can be obtained.

Conclusion

In this project work, we can monitor the status of all the phases simultaneously and for any unbalanced phase, we can detect it, updates the load parameter to the power house on time efficiently and if the microcontroller timer times out it can auto retrieve to the normal operating condition. Thus with the recorded data we can identify the theft current and load interruption in which transmission line phase is maximum.

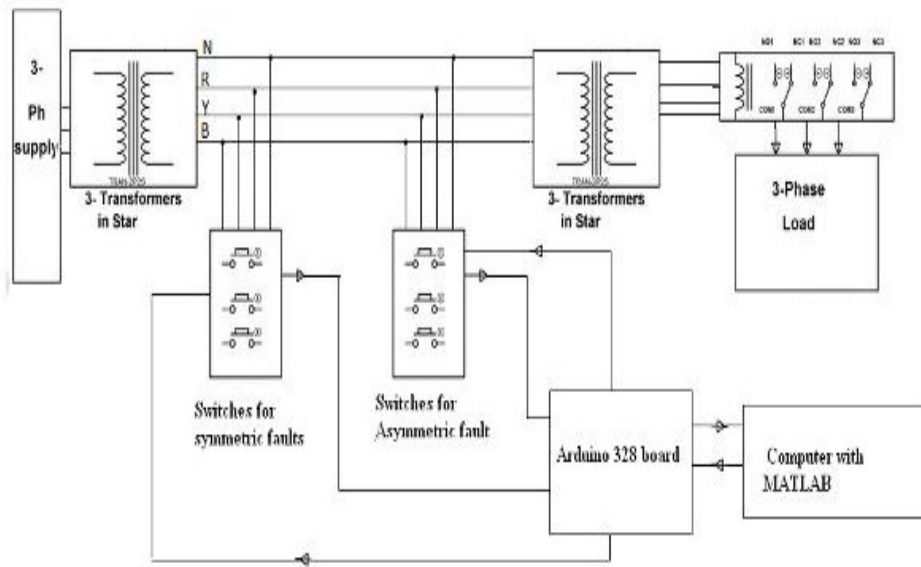

Figure-5
Block diagram of fault detection system

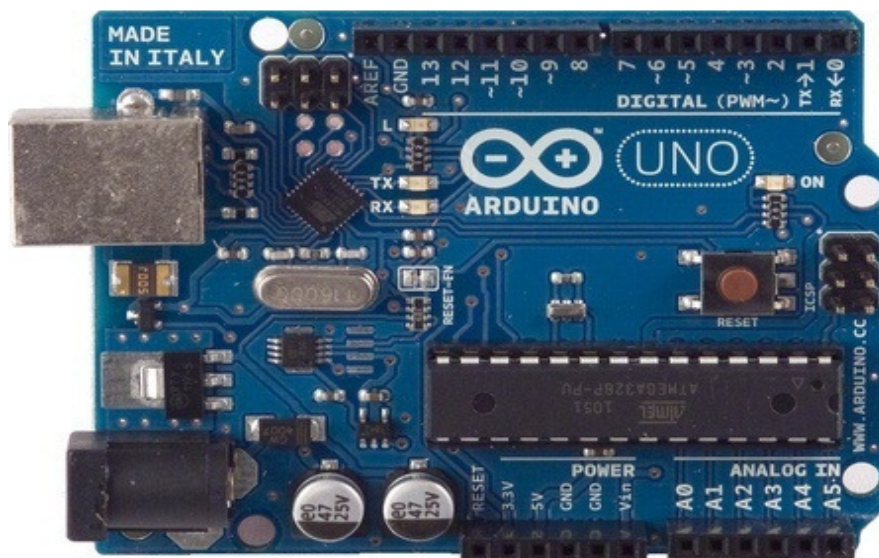

Figure-6
Overview of Arduino 328

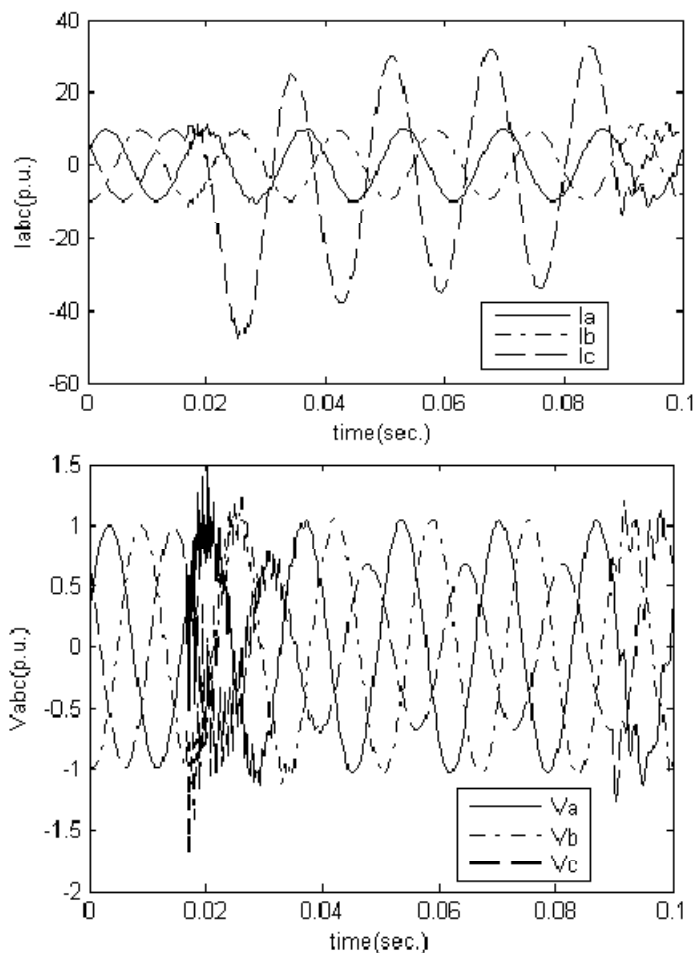

Figure-7
Expected result for detecting fault

Acknowledgement

I would like to thanks Dr. Manisha Sharma, (HOD) of Electronics and telecomm department, BIT Durg and Mr. R.M Potdar, Sr. Associate Professor of Electronics and telecomm department, BIT Durg, for their inspiration, guidance and valuable suggestions.

References

1. Senthil Kumar P. and R. Gowrishankar (2013). Transmission Line Maintenance Using Sensory Data Collection through Rendezvous Nodes. *International Journal of Advanced Research in Electrical, Electronics and Instrumentation Engineering*, 2(4).
2. Kamel T.S. and Moustafa Hassan M.A. (2004). Transmission lines fault detection, classification and location using an intelligent Power System Stabiliser. *IEEE International Conference on Electric Utility Deregulation, Restructuring and Power Technologies (DRPT2004)*, April Hong Kong.
3. Banerjee M.D. and Kulkarni M.N.R. (2013). Three phase Parameter data logging and fault detection using GSM Technology. *International Journal of Scientific and Research Publications*, 3(2).
4. Ghosh A.K. and Lubkeman D.L. (1995). The Classification of Power System Disturbance Waveforms Using a Neural Network Approach, *IEEE Transactions on Power Delivery*, 10(1).
5. Jamil M. Thomas, Moinuddin M.S. and Kumar P. (2013). Fuzzy approach to fault classification for transmission line protection, *Proc. IEEE Tencon 99 Conf.*, 2, 1046–1050.
6. Sumit Shelly vadhera (2011). Iterative and Non-Iterative Methods for Transmission Line Fault-Location Without using Line Parameters. *International Journal of Engineering and Innovative Technology (IJEIT)*, 3(1).
7. Jingjing Cheng, Jing Jin, Li Kong, Huazhong (2005). Wireless Distributed Monitoring and Centralized Controlling System for Prefabricated Substations in China. University of Science and Technology, Hubei, China, *IEEE Journal*.
8. Bramha S.M. (2005). Fault location scheme for a multi-terminal transmission line using synchronized voltage measurements. *IEEE Trans. Power Del.*, 20(2), 1325–1331.