

Simulation of Traditional Composites Under Thermal Loads

Srinivas. G, Prasad Shiva U., Manikandan M. and Kumar Praveen A.

Department of Aeronautical and Automobile Engineering, MIT - Manipal University, Manipal, Udupi Karnataka, INDIA

Available online at: www.isca.in

Received 2nd October 2012, revised 28th December 2012, accepted 21th January 2013

Abstract

Functionally Graded Materials (FGM) has continuous variation of material properties from one surface to another. The gradation of properties in an FGM reduces the thermal stresses, residual stresses, and stress concentrations found in traditional composites. This paper will explore analysis of FGM flat plates under pressure i.e. thermal loading in order to understand the effect variation of material properties has on structural response. Theoretical formulation of various material properties is done using Rule of mixtures. The plate is then modeled and subjected to specific boundary conditions after which thermal analysis is carried out. The convergence studies with respect to varying mesh and layers are carried out in order to obtain accurate results. When subjected to thermal loads, the displacements and stresses vary with different metal/ ceramic proportions, in addition to this; deflection also varies greatly through the thickness. the variation of the same parameters with changing volume fraction of ceramic is also understood. Results are compared to published results in order to show the accuracy of modeling FGMs using ANSYS software.

Keywords: Composites, structural, thermal, mesh size.

Introduction

It is known that the strength of a metal is reduced after it has been in a high-temperature environment for a period of time; beside metal has a low melting point. Moreover, ceramic materials have excellent characteristics in strength and heat-resistance; nevertheless, due to their low toughness their applications are usually limited. In order to solve this problem, FGM's were proposed in Japan in around 1984–1985 during a space plane project and then developed to address the needs of aggressive environment of thermal shock. FGM's are composites consisting of two different materials with a gradient composition, i.e. both the composition and the structure gradually change over the volume, resulting in corresponding changes in the properties of the material. The materials can be designed for specific function and applications. These materials are attracting attention because they can provide for new combined functions that surpass the characteristics specific to each element^{1,4}.

The structural unit of an FGM is referred to as an element or a material ingredient. It is a conceptual unit for constructing an FGM that includes various aspects of its chemical composition, physical state and geometric configuration. In the simplest FGM's, two different material ingredients change gradually from one to the other as shown in figure-1¹.

The material ingredients can also change in a discontinuous way such as the stepwise gradation as illustrated in figure 1



Figure 1
Continuous and Stepwise graded structures¹

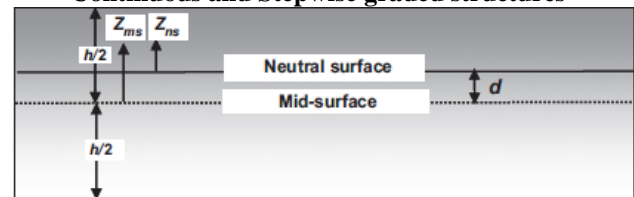

Figure-2
FGM Plate Geometry

This type of structure can also be considered as an FGM. Pores are also important material ingredients of FGM's. A gradual increase in the pore distribution from the interior to the surface can impart many properties such as mechanical shock resistance, thermal insulation, catalytic efficiency, and the relaxation of thermal stress. The creation of multiple or new functions with graded structures, rather than the graded materials itself, is the basis for the FGM concept.

Modeling and design: With the advent of powerful computers and robust software, computational modeling has emerged as a very informative and cost effective tool for materials design and

analysis. Modeling often can both eliminate costly experiments and provide more information than can be obtained experimentally. Computational modeling has clearly played an important role in FGM research to date, and because of the considerable complexity involved, is expected to play an even greater role in future developments. A wide variety of software, for e.g. ABAQUS, ANSYS etc., are commercially available and can be used to model and analyze FGM's. More specifically, these solutions are designed to predict the bulk thermo mechanical response (e.g. Temperature, displacement, stress, and strain fields) of FGM's subjected to varying thermal or mechanical loading conditions. The ability to accurately predict the temperature, stress, and strain fields is important, since such parameters can strongly affect the performance and structural integrity of FGM components¹.

Material properties: Volume fraction and material properties of FGM's may vary in the thickness direction or in the plane of a plate. There are various methods that have been proposed to find the effective moduli and other properties of a composite of two constituents, some of which are the rule of mixtures, variational approach, micromechanical approaches, empirical approaches, fuzzy logic techniques etc. In this paper work, the estimation of the properties of FGM and thereby its modeling, has been carried out by considering the rule of mixtures. A common approach for estimating the material properties of FGM's is to apply a rule of mixtures². This method gives very approximate values of the effective elastic properties of a composite of two constituents and does not account for the interaction among adjacent inclusions. Although actually not physical or mathematical rules, these relationships can be used to approximate thermal or mechanical properties of a composite material in terms of the individual properties and relative amounts of the constituents. The simplest is the classical linear rule of mixtures (voight estimate) for two constituent materials:

$$P = V_{\alpha} P_{\alpha} + V_{\beta} P_{\beta}$$

where P is a typical property, V is the volume fraction, and the subscripts α and β are used to distinguish the two constituents. The voight estimate is simply a volume based arithmetic mean.

Another well known mixture rule is the harmonic mean

$$P = \frac{P_{\alpha} P_{\beta}}{V_{\alpha} P_{\beta} + V_{\beta} P_{\alpha}}$$

In their most basic form, the above rules of mixtures are employed using bulk constituent properties, assuming no interactions between phases. Because of their simplicity, they are often used for FGM's, since a single relationship can be used for all volume fractions and microstructures. However, also because of their simplicity, their validity is limited.

Methodology

The FGM modeled usually is done with one side of the material

as ceramic and the other side as metal. A mixture of the two materials composes the through-the-thickness characteristics. This material variation is dictated by a parameter, n . At $n = 0$ the plate is a fully ceramic plate while at $n = \infty$ the plate is fully metal. Material properties are dependent on the n value and the position in the plate and vary according to a power law.

$$P(Z) = (P_t - P_b)V_f + P_b$$

$$V_f = \left(\frac{Z}{h} + 0.5 \right)^n$$

A typical material property P is varied through the plate thickness according to the following expressions (a power law). Where P_t and P_b denote the particular property being considered at the top and bottom faces of the plate, respectively, and n is the parameter that dictates the material variation profile through-the-thickness. Z is the location along the thickness, measured from the mid-surface of the plate and h is the thickness of the plate. This volume fraction is based on the mixture of metal and ceramic and is an indicator of the material composition (volumetric wise) at any given location along the thickness. If the volume fraction of ceramic is defined as V_f then the volume fraction of metal is the remainder of the material i.e. $1 - V_f$. E , α and k also vary according to the power law and their calculated values are entered into ANSYS accordingly.

Finite Element Modeling Technique: The units followed throughout this paper are as follows: length [m], pressure [N/m²], temperature [K], CTE [1/K], conductivity [W/mK]. Displacement in the X, Y and Z directions are denoted by U_x , U_y and U_z respectively. Rotations in the X, Y and Z directions are denoted by ROTX, ROTY and ROTZ respectively. Because the material properties of the FGM change throughout the thickness, the numerical model must be broken up into various "layers" in order to capture the change in properties. These "layers" capture a finite portion of the thickness and are treated like isotropic materials. Material properties are calculated at the mid-plane of each of these "layers", from the mid-surface using the power law (3) and (4). The neutral surface and mid-surface of the FGM plate do not always coincide with each other; hence in the case of neutral surface based formulation, the coordinate z is with respect to the neutral surface. The volume fraction of ceramic (V_f) in the new coordinate system can be expressed as follows⁴.

$$V_f = \left(\frac{Z}{h} + \frac{d}{h} + 0.5 \right)^n$$

where d is the distance of the neutral surface from the geometric mid-surface and it is illustrated in figure-2⁴. The "layers" and their associated properties are then layered together to establish the through-the-thickness variation of material properties. Although the layered structure does not reflect the gradual

change in material properties, a sufficient number of “layers” can reasonably approximate the material gradation. In this paper, the modeling and analysis of FGM plate is carried out using ANSYS software. ANSYS offers a number of elements to choose from for the modeling of composite materials. The FGM characteristics under mechanical and thermal loads studied on a flat plate were modeled in 3-D. In this project, for analysis under mechanical loads, Solid186 is used whereas for thermal as well as thermo mechanical analysis Solid90, a higher order thermal element is used to get more accurate results.

Modeling and Meshing: The square plate modeled is meshed using the mesh tool. The mesh tool provides a convenient path to many of the most common mesh controls, as well as to the most frequently performed meshing operations. The mesh tool is an interactive "tool box", because of the numerous functions it incorporates.. Using the mesh tool, the edges of the model along the thickness are divided into the number of layers desired; the other edges are then selected and divided depending on the mesh size required. The following figure-3 shows an FGM plate modeled with 8 layers and a mesh count of size 8x8 along the x-y plane.

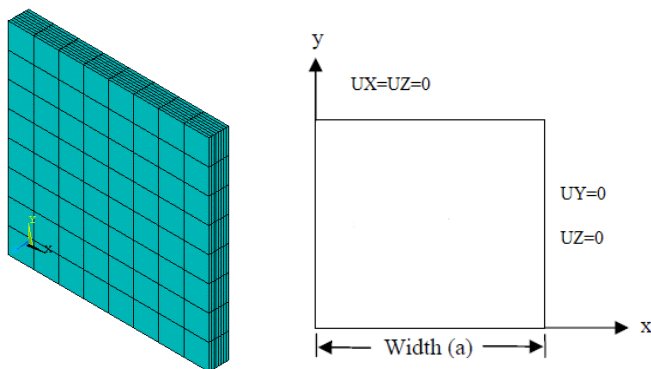

Figure-3

Square plate with 8 layers, 8x8 mesh and Simply supported boundary condition

The mesh tool is an interactive "tool box", because of the numerous functions it incorporates.. Using the mesh tool, the edges of the model along the thickness are divided into the number of layers desired; the other edges are then selected and divided depending on the mesh size required. The following figure-3 shows an FGM plate modeled with 8 layers and a mesh count of size 8x8 along the x-y plane.

Once the model is meshed; the model is modified in order to create layers with different material properties. This is done with the help of component manager. Using component manager, the elements present along the same layer are grouped together to assign particular material properties to those layers. The material properties are then assigned to the respective

layers defined along the thickness. It is to be noted that each layer is isotropic in nature. Figure 4 shows the FGM plate with different material properties assigned to each layer.

Boundary Conditions: The plate modeled throughout this project is subjected to simply supported Boundary condition i.e. along the X direction, $U_x=U_z=0$ and along the Y direction $U_y=U_z=0$. It is illustrated in figure-3.

Results and Discussion

Analysis under thermal loads: The study of the behaviour of the FGM plate under thermal loads is done for a square FGM plate model made of Monel/ zirconia. We aim to characterize the effect n has on the structural response under thermal loading. The analysis results were validated against the published results⁵. The top surface of the plate is ceramic (Zirconia) rich and the bottom surface is metal (Monel) rich. The material properties considered for the present analysis are $E_{cer}=151Gpa$, $\nu_{cer}= 0.3$, $\alpha_{cer}=10 \times 10^{-6} /K$, $k_{cer}=2.09 W/mK$, $E_{met}=180Gpa$, $\nu_{met}= 0.368$, $\alpha_{met}=15 \times 10^{-6} /K$, $k_{met}=25W/mK$. where E is Young’s modulus, ν is Poisson’s ratio, α is Co-efficient of thermal expansion and k is thermal conductivity⁶. The volume fraction of the ceramic phase is calculated using equation.

$$V_f = \left(\frac{z}{h}\right)^n$$

The through thickness variation of volume fraction V_f for $n=0.5$, 1 and 2 of a Monel/Zirconia plate of 8 layers. The bottom surface of the FGM plate is metal-rich and the top surface is ceramic-rich. In actual service conditions, zirconia top coat is typically employed as a thermal barrier on Ni-based structural components in aircraft engines.

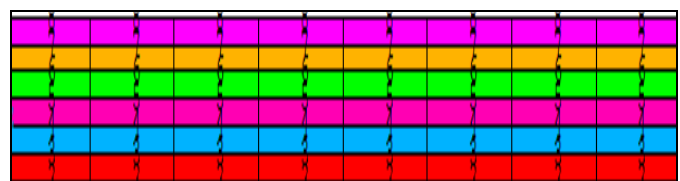

Figure-4

FGM plate layers with different material properties

A steady state, heat-conduction analysis is carried out on the FGM plate under thermal loading. The element chosen is SOLID90, a higher-order thermal element. In order to get the structural response of this FGM plate under thermal load, the element is switched to its corresponding structural element i.e. SOLID186, while applying the structural boundary conditions.

Convergence study of FGM plates under Thermal Loads: In order to obtain accurate results, a convergence study of FGM

plate, with respect to varying mesh size and varying number of layers is carried out. This study is carried out on a simply supported thick square plate ($a/h=10$) for $n=2$. The edges as well as the bottom surface of the plate are maintained at zero temperature. The top surface of the plate is subjected to a sinusoidal temperature load as follows; where $T=100K$.

$$T^+ = T \sin\left(\frac{\pi x}{a}\right) \sin\left(\frac{\pi y}{b}\right)$$

$$u_i^* = \frac{u_i(z)}{pa}; \sigma_{ij}^* = \frac{\sigma_{ij}(z)}{pk}; T^* = \frac{\alpha T(z)}{p}$$

The following table-1 and table-2 shows the convergence study of an FGM simply supported plate with respect to varying mesh and varying number of layers respectively. The study shows that as the mesh size increases the values of displacements and stresses converges to the published results. The convergence is achieved earlier; because for the use of higher order elements a coarse mesh is enough to obtain accurate results. The study is carried out only till 50×50 mesh due to the constraint of computer memory space availability.

Effect of n: The effect of n on the structural response of the FGM plate under consideration is studied under thermal loads. A thick ($a/h=10$) plate was modeled with 8 layers and a mesh size of 50×50 in order to get more accurate results. The edges as well as the bottom surface of the plate are maintained at zero temperature. The analysis has been carried out for $n=0.5, 1$ and 2 . The following table-2 shows the effect of n on the non-dimensionalized displacements and stresses of an FGM plate. The parameters are non-dimensionalized using equation⁷ as shown above.

It is observed that the obtained values of temperature are higher as compared to the published results. This accounts for the fact that the values of stresses are also higher as compared with the published results. The temperature, transverse displacement, normal stresses and transverse normal stress are measured at the centre of the plate whereas; the in-plane displacement and transverse shear stress at the left side of the plate see figure-5 to 10. This is because the peak values of these parameters are observed at the side of the plate as shown in the following contour plots.

Table-1

Convergence study of simply supported thick FGM plate under thermal load with respect to varying mesh size

Parameter	z/h	8x8	12x12	20x20	50x50	Published
T	0.5	0.27778	0.27784	0.27786	0.27786	0.2432
u _x	0	0.0536	0.0535	0.0532	0.0532	0.08492
	0.5	-0.862	-0.862	-0.863	-0.863	-0.7862
	1	-1.82	-1.82	-1.82	-1.82	-1.699
u _z	0	5.79	5.79	5.80	5.80	5.522
	0.5	5.93	5.93	5.93	5.93	5.635
	1	6.34	6.34	6.34	6.34	6.021
σ _{xx}	0	-49.1	-48.6	-47.7	-47.7	-75.78
	0.5	-301	-327.0	-322	-322	-243.0
	1	-1120	-1100	-1090	-1090	-1006
σ _{zz}	0.5	0.850	0.8578	0.81956	0.81956	1.015
σ _{xz}	0.5	2.25	2.2434	2.2178	2.2178	1.583

Table-2

Convergence study of simply supported thick FGM plate under thermal load with respect to varying number of layers

Parameter	z/h	6 Layers	8 Layers	9 Layers	Published results ⁵
T	0.5	0.28442	0.27786	0.27694	0.2432
u _x	0	0.0596	0.0532	0.0516	0.08492
	0.5	-0.888	-0.863	-0.854	-0.7862
	1	-1.88	-1.82	-1.80	-1.699
u _z	0	6	5.80	5.73	5.522
	0.5	6.13	5.93	5.86	5.635
	1	6.56	6.34	6.27	6.021
σ _{xx}	0	-53.4	-47.7	-46.3	-75.78
	0.5	-335	-322	-300	-243
	1	-1110	-1090	-1090	-1006
σ _{zz}	0.5	0.91686	0.81956	0.78232	1.015
σ _{xz}	0.5	2.5475	2.2178	1.9867	1.586

Table-3
 Percentage error calculation of displacements and stresses
 for a simply supported thick FGM plate, under thermal load

Parameter	z/h	Ansys Results	Published Results[5]	% Error
T	0.5	0.27786	0.2432	14.2516
u_x	0	0.0532	0.08492	-37.3528
	0.5	-0.863	-0.7862	9.7685
	1	-1.82	-1.699	7.1218
u_z	0	5.80	5.522	5.0344
	0.5	5.93	5.635	5.2351
	1	6.34	6.021	5.2981
σ_{xx}	0	-47.7	-75.78	-37.0546
	0.5	-322	-243	32.5102
	1	-1090	-1006	8.349
σ_{zz}	0.5	0.81956	1.015	-19.255
σ_{xz}	0.5	2.2178	1.583	40.101

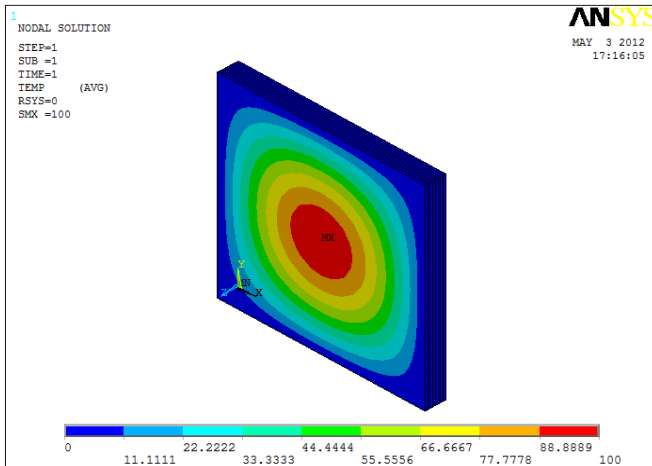

Figure-5

Temperature (T) distribution for n=2 under Thermal load

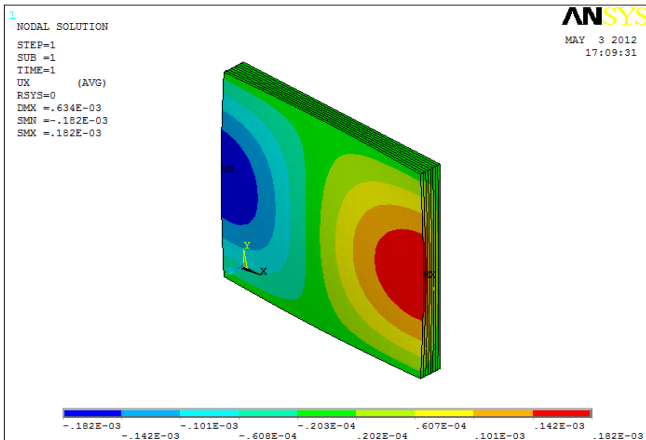

Figure-6

In-plane displacement (u_x) distribution for n=2 for thermal load

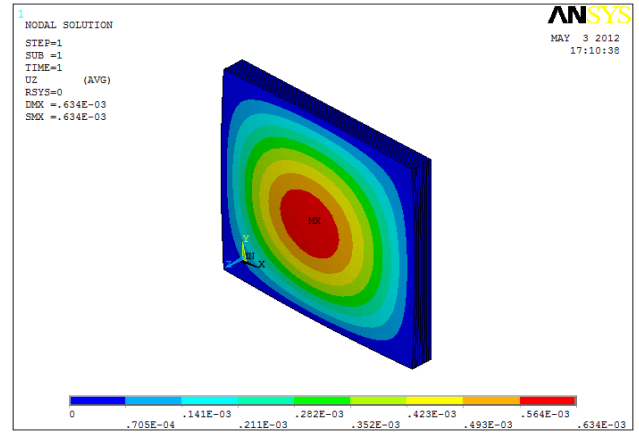

Figure-7

Transverse displacement (u_z) distribution for n=2 under thermal load

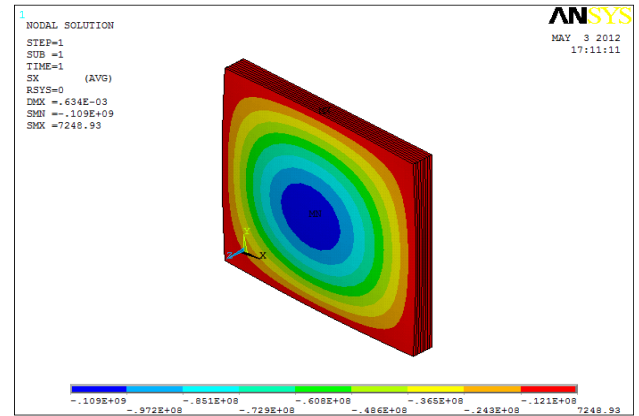

Figure-8

Normal stress (σ_{xx}) distribution for n=2 under thermal load

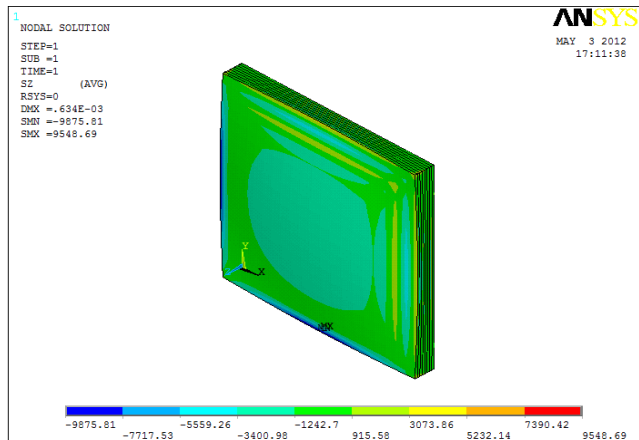

Figure-9

Transverse shear stress (σ_{xz}) distribution for n=2 under thermal load

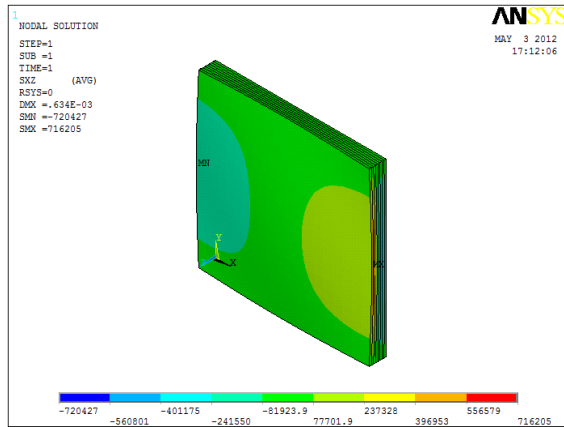

Figure-10

Transverse shear stress (σ_{xz}) distribution for $n=2$ under thermal load

The above study shows that the distribution of temperature, T and the resulting in-plane displacement u_x are only slightly altered by varying n . The transverse displacement of the plate under the thermal load greatly changes through the thickness. Also the maximum compressive normal stress appears on the top surface of the plate.

The percentage error for $n=2$ is calculated and shown in the following table 3 in order to show accuracy of the present ANSYS modelling with the published results⁵.

From figure 5-10 show the contour plots for various parameters evaluated for a simply supported FGM plate under thermal load ($n=2$)

Conclusion

Functionally Graded Materials (FGM) have continuous variation of material properties from one surface to another. The gradation of properties in an FGM reduces the thermal stresses, residual stresses, and stress concentrations found in traditional composites. It also allows the designer to tailor material response to meet design criteria. An FGM made of ceramic and metal can provide the thermal protection and load carrying capability in one material and hence is advantageous over traditional materials. In this paper, analysis is carried out on an FGM square plate made of Monel/Zirconia. The plate considered is a thick plate with $a/h=10$ and $a/b=1$. The structural response of this plate is studied with respect to thermal loads.

Initially, convergence study with respect to varying mesh size and varying number of layers is carried out. It is observed that more number of layers and finer mesh give more accurate results. Based on this study, the mesh size and number of layers

required for further analysis is fixed. When subjected to thermal loads the distributions of temperature and the resulting in-plane displacement are altered. Also, the transverse displacement of the plate under the thermal load changes greatly through the thickness. The structure may be modelled with varying values of n depending on the function the material is required to perform. The results obtained using ANSYS software when compared to the published results shows certain percentage of error. This is due to the element chosen as well as the mesh size and the number of layers. The higher order element gives better result. Another factor that may contribute to the same is modelling errors made by the user.

Future scope: The plate modeled here-in was a step-wise graded structure, with each layer being isotropic with specific material properties. The material properties for each layer were calculated manually using linear rule of mixtures. Other methods like Reuss estimate, Mori-Tanaka scheme can be used which may give better estimation of properties. Another way to do so is by programming a code, in order to get continuous variation of properties. Hence continuous graded FGM's may also be modelled. Fluid-structure interaction (FSI) studies may be carried out on the FGM plate modelled.

References

1. Miyamoto Y. and Kaysser W.A., Functionally Graded Materials – Design, Processing and Applications, Kluwer Academic Publishers, (1999)
2. Ghosh A. and Reimanis Ivar, Functionally Graded Materials: Manufacture, Properties and Applications Ceramic Transactions, **76**, (1997)
3. Cooley William and Captain G., USAF, Application of Functionally Graded Materials in Aircraft Structures, Thesis work, March (2005)
4. Singha M.K., Prakash T. and Ganapathi M., Finite element analysis of functionally graded plates under transverse load, Finite Elements in Analysis and Design **47**, 453–460 (2011)
5. Reddy J.N. and Zhen-Qiang Cheng, Three-dimensional thermomechanical deformations of functionally graded rectangular plates, Department of Mechanical Engineering, Texas A and M University, College Station, TX 77843-3123, USA, (2001)
6. Suresh A. Mortensen, Fundamentals Of Functionally Graded Materials – Processing and Thermo- Mechanical Behavior of Graded metals and Metal-Ceramic Composites, IOM Communications, (1998)