

Modeling and Simulation of Pitch and Yaw Angle Control in Unmanned Under Water Vehicle

Bhupendra kumar* and Ekta Tamrakar

Department of Electronics and Telecommunication Engineering, Bhilai Institute of Technology Durg, India
bhupendrabilai@gmail.com

Available online at: www.isca.in, www.isca.me

Received 24th February 2016, revised 8th March 2016, accepted 23rd April 2016

Abstract

In various research and experimental areas under the water without human intervention we need a vehicle which can do the required task is known as “unmanned under water vehicle”. In this project we will efficiently model the system and perform the various simulation tasks for pitch angle and yaw angle control by using various control techniques. By using these control techniques we will obtain the best possible performance technique to control the pitch angle and yaw angle and also here we will close compare the various parameters of different controllers.

Keyword: Matlab, P, PI, PD, PID controllers.

Introduction

As we know that 70% of the Earth is covered with water and in order to explore various resources under oceans, mankind depends on developing underwater vehicles and employing them. There are various types of underwater vehicles which can be classified into two categories as manned and unmanned under water systems. In various research and experimental areas under the water without human intervention we need “unmanned under water vehicle”¹.

In manned under water system, we have military submarines and non-military submersibles vehicle operated for Underwater exploration and assessment. An Autonomous Underwater Vehicle (AUV) is an undersea system which use self power and controlled by an onboard embedded computer while doing a specified task¹.

Pitch angle: Pitch angle is controlled by pitch control system. Figure-1 shows the representation of pitch angle and

corresponding pitch control loop is shown in Figure-2. In pitch control loop we will control the pitch angle by using the elevator actuator.

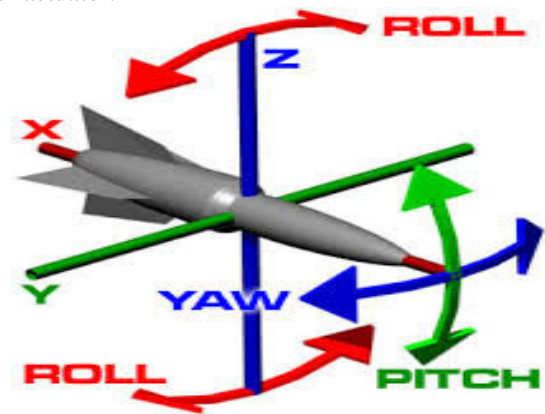

Figure-1
Representation of pitch and yaw angle

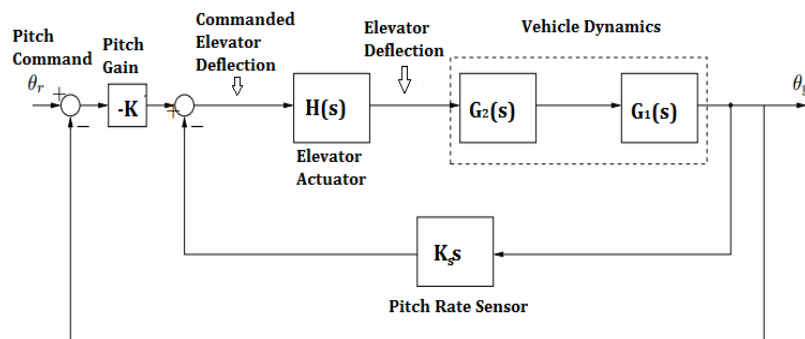

Figure-2
pitch control system

Yaw angle: Yaw angle is controlled by heading control system. Figure-1 shows the representation of yaw angle and corresponding heading control loop is shown in Figure-3. In heading control loop we will control the yaw angle by using the rudder actuator.

Materials and Methods

Material: For this research project we mainly use matlab software for modelling and simulation.

Methods: Pitch control system: From Figure-2 the respective block equation of elevator actuator and vehicle dynamics are:

$$H(s) = \frac{2}{(s+2)} \tag{1}$$

$$G1(s) = \frac{-0.125(s+0.435)}{s^2+0.226+0.0169} \tag{2}$$

$$G2(s) = \frac{(s+0.435)}{(s+1.23)} \tag{3}$$

Open loop system: The open loop system are:

$$G(s) = \frac{-0.125*2(s+0.435)}{(s+2)(s+1.23)(s^2+0.226s+0.0169)} \tag{4}$$

And the step response of this system is shown in Figure-4.

Close loop system: Close loop system are:

$$\frac{\theta_y(s)}{\theta_r(s)} = \frac{0.25*k1(s+0.435)}{s^4+3.456s^3+3.457s^2+(0.719+0.25k1)s+(0.0416+0.109k1)} \tag{5}$$

By using Routh-Hurwitz criteria the stability range of this system are- $0 < k < 25.87$

Now the response of this system for different value of k is shown, Figure-5 show response using $k=5$, Figure-6 show response using $k=20$.

Heading control system: From Figure-3 the respective block equation of rudder actuator and vehicle dynamics are:

$$H(s) = \frac{2}{(s+2)} \tag{6}$$

$$G(s) = \frac{-0.125(s+0.435)}{s(s+1.29)(s+0.193)} \tag{7}$$

Open loop system: The open loop system are:

$$G(s) = \frac{-0.125(s+0.435)}{(s+2)(s+1.29)(s+0.193)s} \tag{8}$$

And the step response of this system is shown in Figure-7.

Close loop system: close loop system are:

$$\frac{\theta_y(s)}{\theta_r(s)} = \frac{0.25*k1(s+0.437)}{s^4+3.483s^3+3.4649s^2+(0.60705+0.25k1)s+(0.10925k1)} \tag{9}$$

By using Routh-Hurwitz criteria the stability range of this system are- $0 < k < 26.43$. Now the response of this system for different value of k is shown, Figure-8 show response using $k=5$, Figure-9 show response using $k=15$.

Hence we have discussed here the response for proportional controller, to improve the response we will use PI, PD, PID controller.

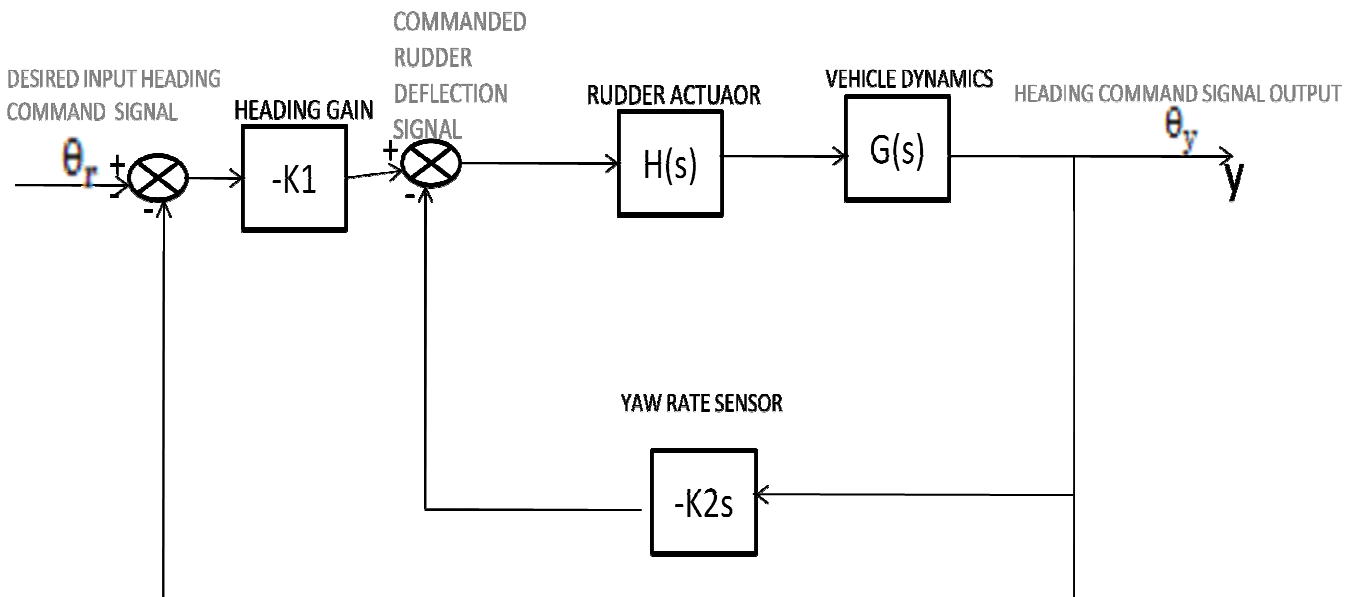

Figure-3
Heading control system

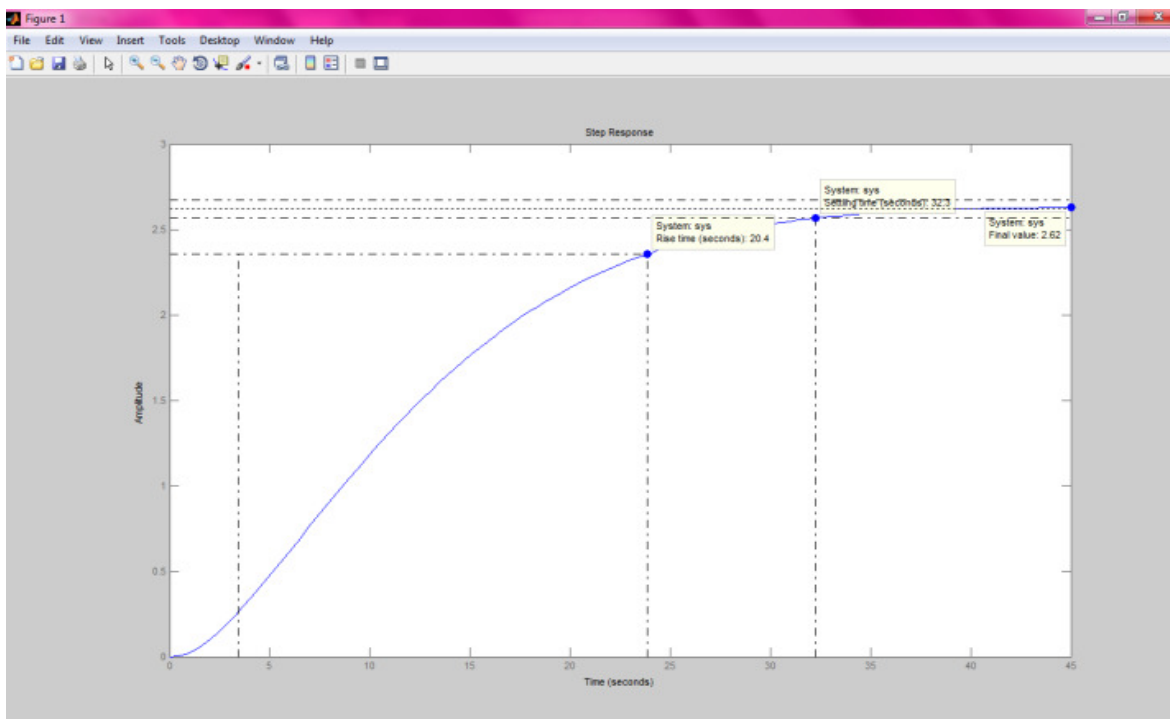

Figure-4
Step response of open loop pitch control system

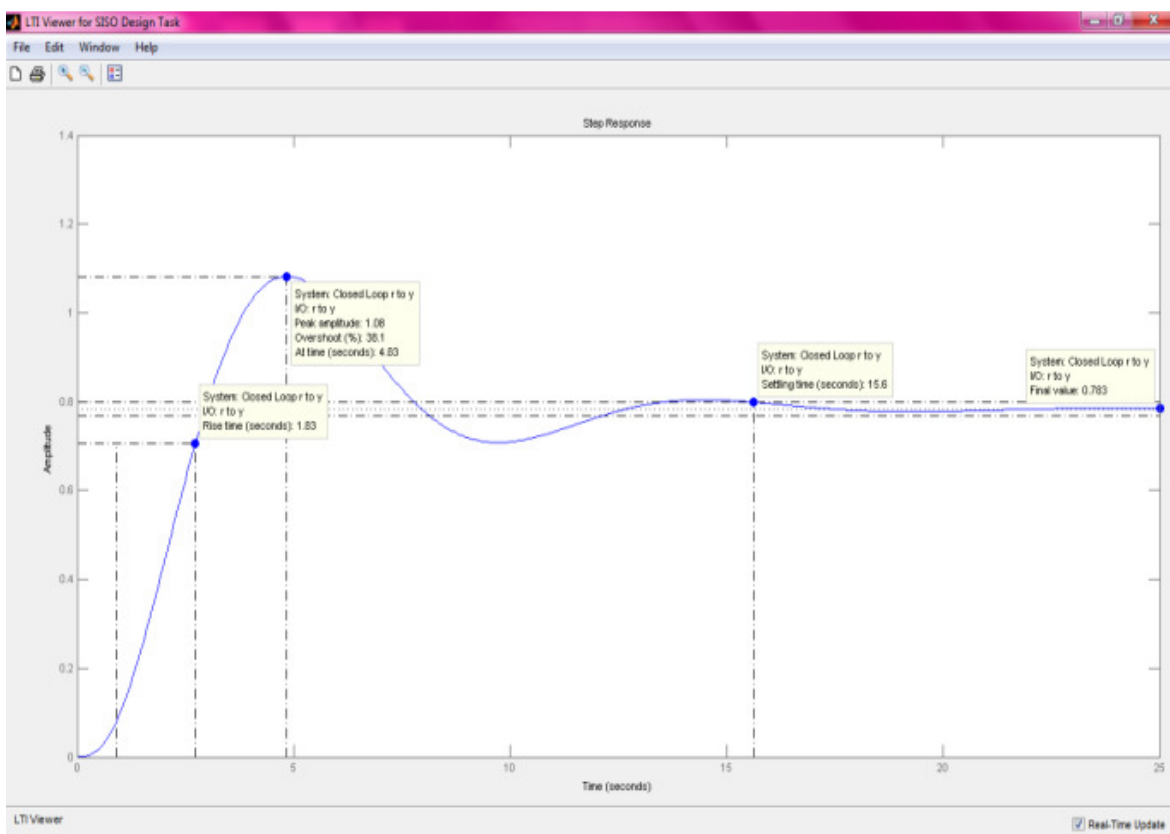

Figure-5
Pitch control system response for k=5

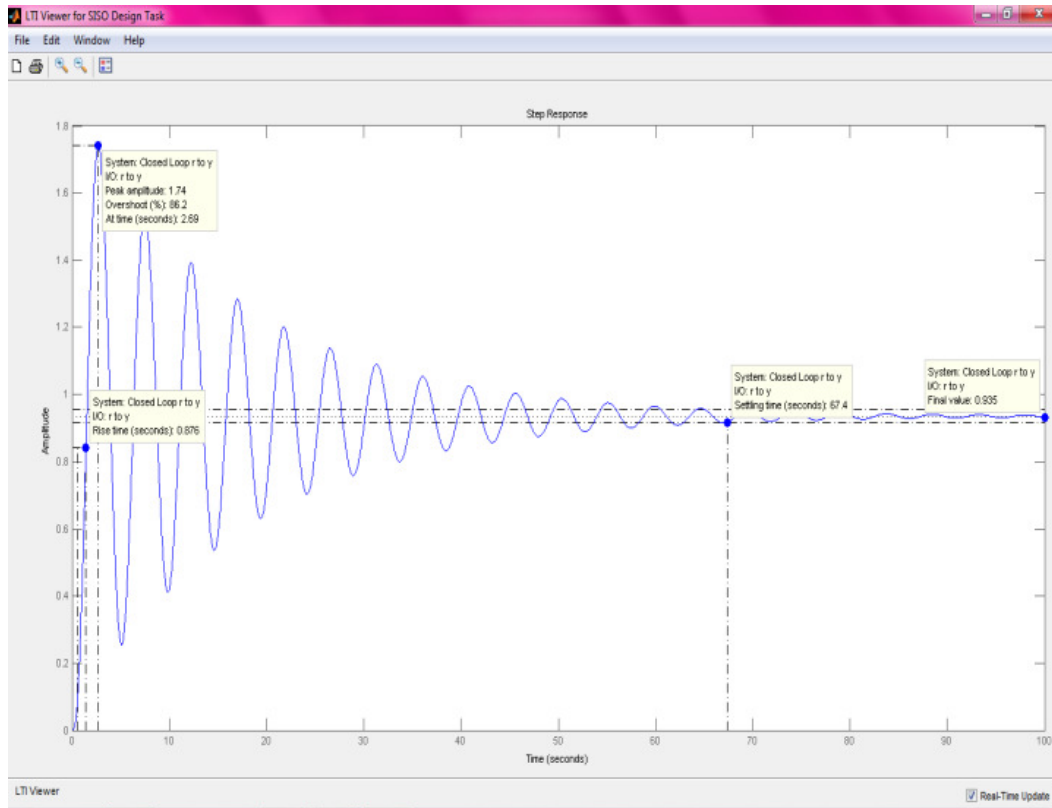

Figure-6
Pitch control response for $K=20$

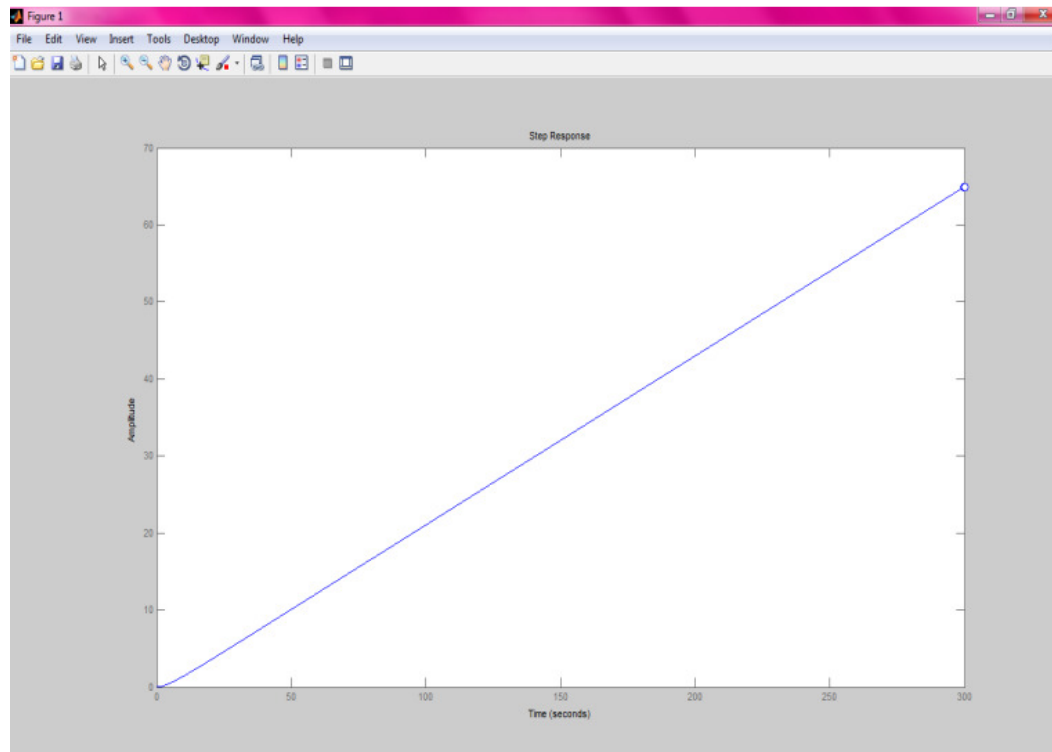

Figure-7
Step response for open loop heading control system.

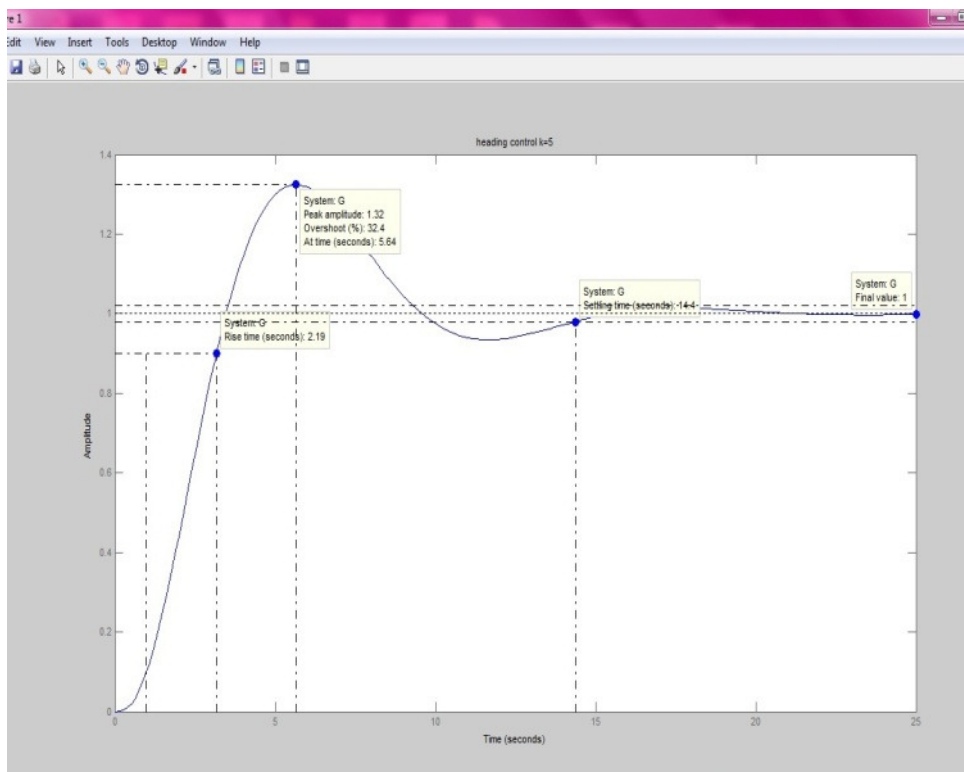

Figure-8
Heading control system response for k=5.

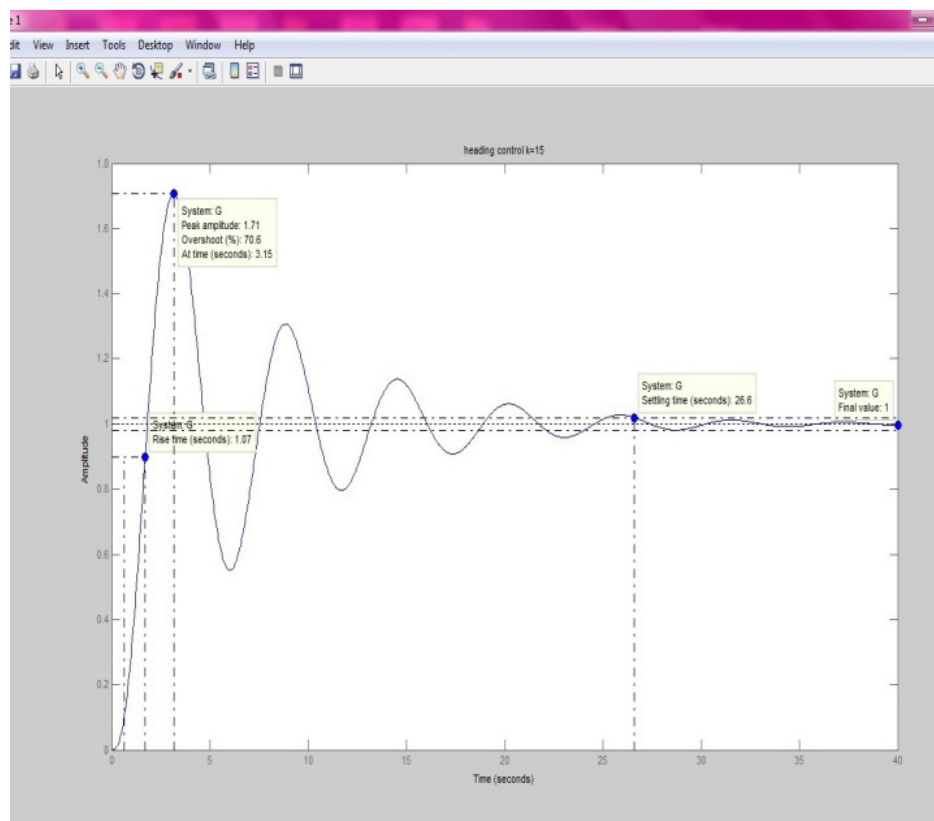

Figure-9
Heading control system response for k=15

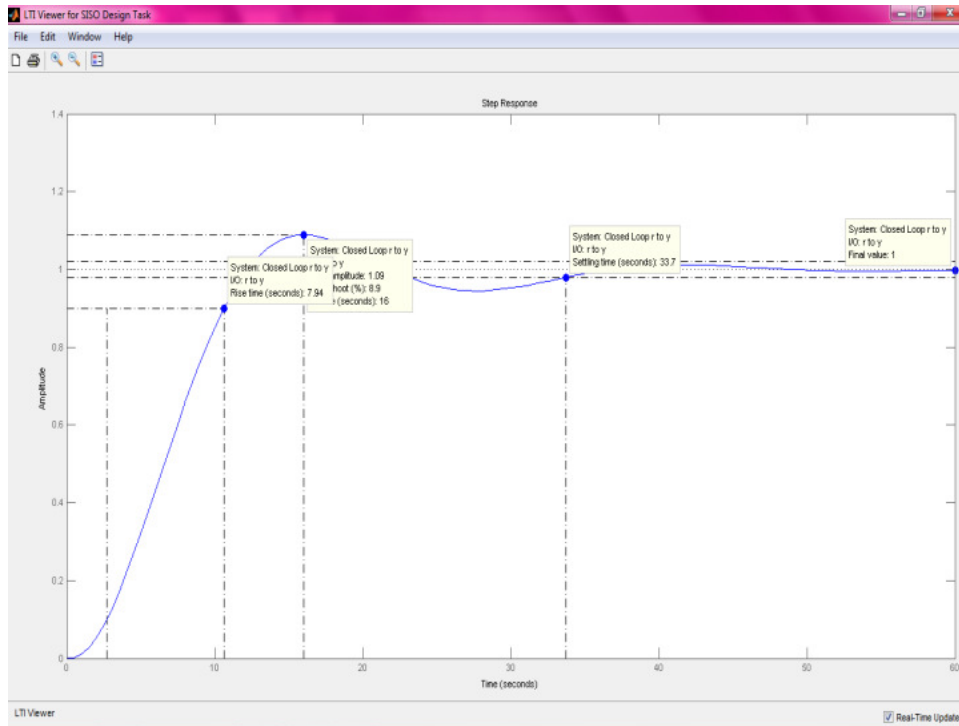

Figure-10
Pitch control system using PI controller.

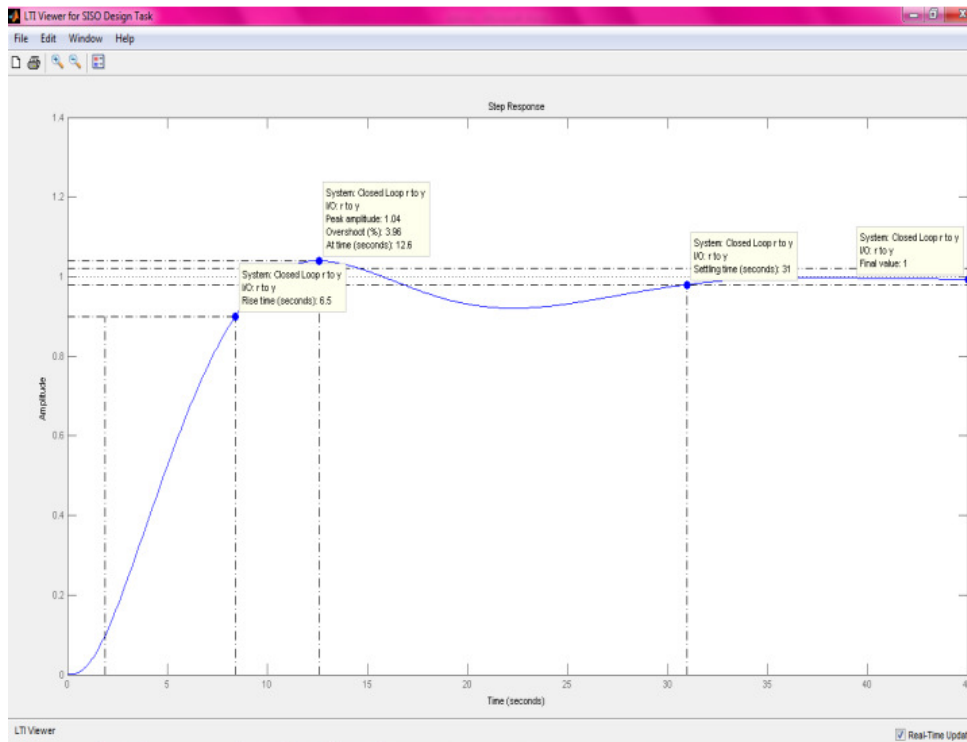

Figure-11
Heading control system using PI controller

PI controller: Now by using pidtool and sisotool in MATLAB the response are- Pitch control system: Figure-10 shows step response of this system. Heading control system: Figure-11 shows response using this system.

PD controller: Using pidtool and sisotool in MATLAB the response of this system. Heading control system: Figure-13 shows step response using this system. Pitch control system: Figure-12 shows step response using this system.

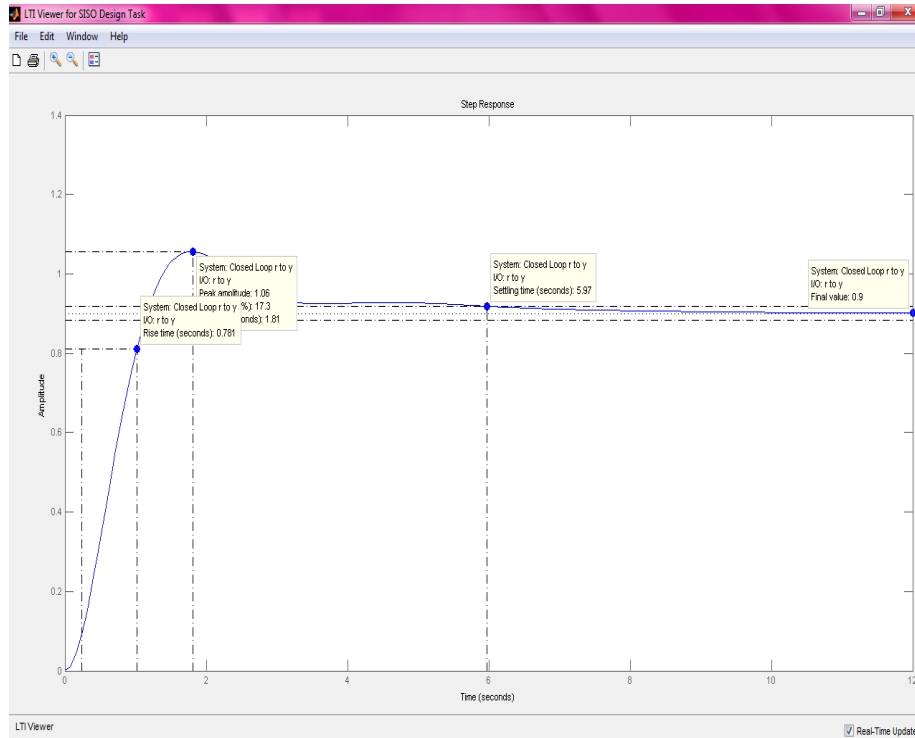

Figure-12
Pitch control system using PD controller

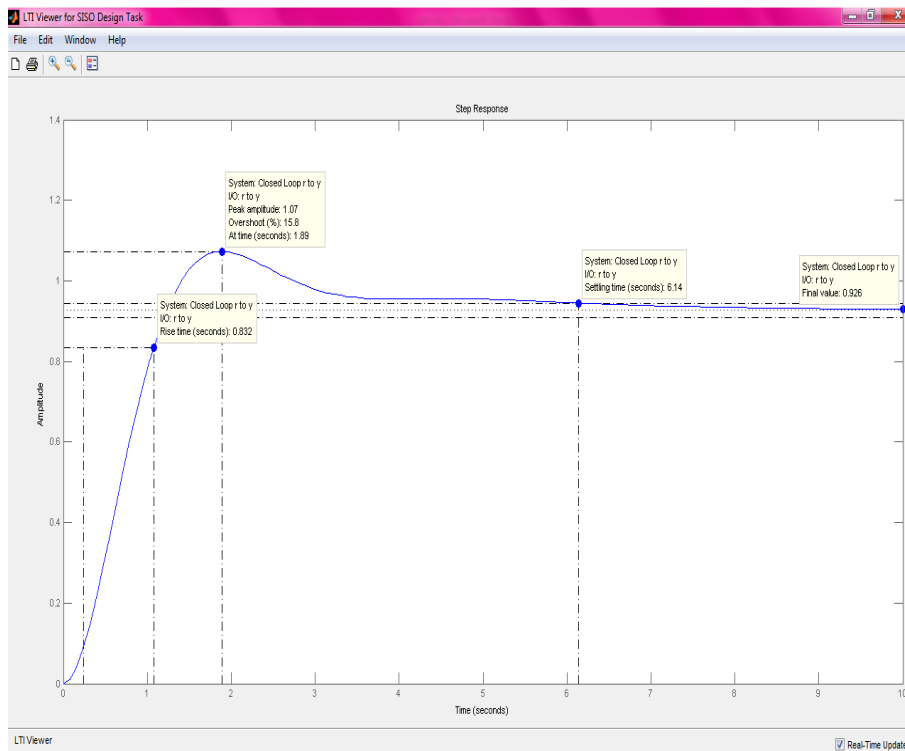

Figure-13
Heading control system using PD controller

PID controller: Using pidtool and sisotool in MATLAB the response of this system. Heading control system: Figure-15 shows step response using this system. Pitch control system: Figure-14 shows step response using this system.

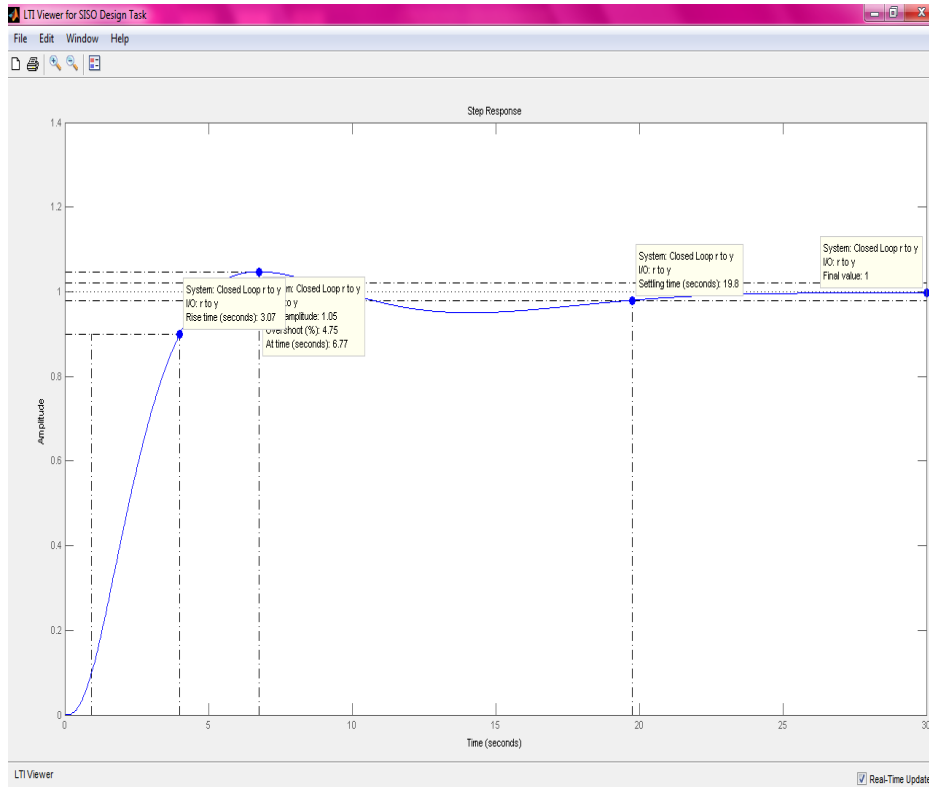

Figure-14
Pitch control system using PID controller

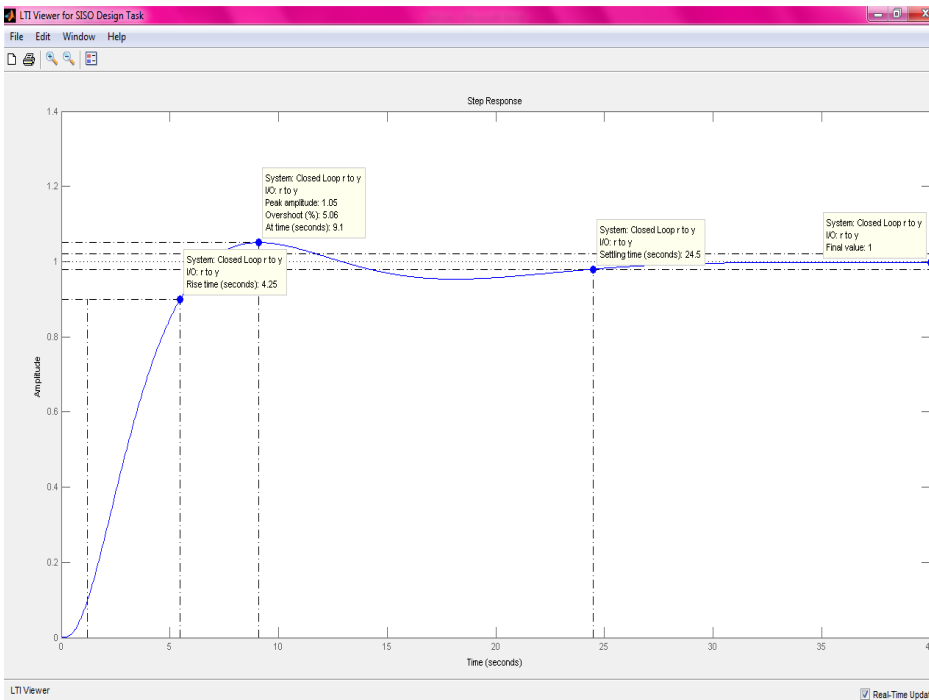

Figure-15
Heading control system using PID controller

Results and Discussion

Using the above control technique i.e. P, PI, PD, PID the result of various parameters of different controllers for pitch control system shown in Table-1 and for heading control system shown in Table-2².

Table-1
Parameters for pitch control system

Parameters	K=5	K=20	PI	PD	PID
Tr (sec)	1.83	0.876	7.94	0.781	3.07
Tp (sec)	4.63	2.69	16	1.81	6.77
Ts (sec)	15.6	67.4	33.7	5.97	19.8
Overshoot (%)	38.1	86.2	8.9	17.3	4.75
Peak amp.	1.06	1.74	1.09	1.06	1.05

Table-2
Parameters for heading control system

Parameters	K=5	K=15	Pi	Pd	Pid
Tr(sec)	2.19	1.07	6.5	0.832	4.25
Tp(sec)	5.64	3.15	12.6	1.89	9.1
Ts(sec)	14.4	26.6	31	6.14	24.5
Overshoot(%)	32.4	70.6	3.96	15.8	5.09
Peak amp.	1.32	1.71	1.04	1.07	1.05

Conclusion

In this paper pitch and yaw angle control system have been simulated by P,PI,PD and PID controller and the outcome of various parameter values is shown in tables. From this analysis we are conclude here that PD controller is giving improved response as compare to other controller except overshoot which is minimum in case of PID controller³.

Acknowledgement

We express our thanks to Mr. R. M. Potdar, Sr. Associate Professor, Dept. of ETC, BIT Durg and acknowledge the timely help of Dr. T. Siva Kumar, Sr. Associate Professor, Dept. of ETC, BIT Durg. We warmly thank Dr. Manisha Sharma, HOD Dept. of ETC, BIT Durg for her kind support and guidance. We render our indebtedness to Dr. Arun Arora, Principal, BIT Durg for his constant encouragement given to us throughout the research work. Above all, I render my gratitude to the supreme almighty authority who bestowed self confidence, ability, and strength in me to complete this work.

References

1. Mahendra Pratap Singh, Bilas Chowdhury (2011). Control of autonomous underwater vehicles (Unpublished dissertation). Department of Electrical Engineering National Institute of Technology Rourkela.
2. Nise S. Norman (2015). Control System Engineering, John Wiley and Sons, Sixth Edition, international student edition, India, endpapers, ISBN:978-81-265-3728-0.
3. Mohammad jawed masud, Faisal fayyaz qureshi and Abdul rehman chishti (2014). Comparison of pitch control system for an unmanned free-swimming submersible vehicle with pd controller and linear quadratic regulator using matlab. Tomul LX (LXIV), Fasc. 3-4, 20.
4. Khalid ISA and MR Arsad (2012). Buoyancy driven under water glider modeling and analysis of motion control. *Indian journal of geo marine*, 41(6), 516-526.
5. Maziyah mat noh, Mohd rizal arshad and Rosmiwati mohd mokhtar (2011). Depth and pitch control of USM underwater glider: performance comparion PID vs LQR. *Indian journal of geo marine science*, 40(2), 200-06.
6. Preeti and Dr. Narendra Singh Beniwal (2012). Comparison of Conventional and Fuzzy P/PI/PD/PID Controller for Higher Order Non Linear Plant with High Dead Time. *International Journal of Scientific and Research Publications*, 2, ISSN 2250-3153.