



Review Paper

## A Review on Battery Super capacitor Hybrid Storage System

Rashmi Tiwari, Mousam Sharma, Mukesh Ku Chandrakar

BIT, Durg, Chhattisgarh, India  
laxmikantpatil996@gmail.com

Available online at: [www.isca.in](http://www.isca.in), [www.isca.me](http://www.isca.me)

Received 3<sup>rd</sup> September 2021, revised 25<sup>th</sup> March 2022, accepted 19<sup>th</sup> April 2022

### Abstract

*Electric vehicles (EVs) have actually pulled in critical thought accordingly did the headway of the battery developments. Yet the battery development has been basically front line, the open batteries don't totally fulfill the energy needs of the EV power use. One of the central requests is non-monotonic use of energy joined by unremitting changes during the battery conveying participation. This is incredibly malevolent to the electrochemical course of the battery. A practical arrangement is to couple the battery with a supercapacitor, which is by and large an electrochemical cell with a relative arrangement, however with a higher rate limit and better cyclability. In this plan, the supercapacitor can give the wealth energy required while the battery neglects to do taking everything into account. In any case the battery and supercapacitor as the singular units, organizing the arrangement of the relating cream system as indicated by an electrical planning viewpoint is of most outrageous importance. The current creation studies the new works provided for the utilization of various battery/supercapacitor cross variety systems in EVs.*

**Keywords:** Battery, supercapacitor, hybrid storage, review.

### Introduction

Utilization of electric vehicles is creating bit by bit owing to its monetary and normal benefits. The endeavor's guideline justification behind existing is to diminish internal consuming engine (ICE) fuel usage. The demonstration of any Electric Vehicle improvement relies on the gadget for dealing with energy. The proposed structure is to squashed the way that by adding super capacitor the battery thinks especially the electrical nerves are the. The proposed Creamer Energy Accumulating Structure (HESS) was wanted to empower battery and super condenser to satisfy most over the top force needs during Electric Vehicle (EV) speed increase. The paper's central limit is to develop the Electric Vehicle's battery life and generally execution anyway the use of super condenser. The batteries can in like way be protected from high pinnacle streams, taking into account the super capacitor. The super capacitor module can be used identified with the batteries in the limit structure to achieve benefits like overhauling vehicle speed increment, further creating overall drive execution, therefore growing the driving reach, diminishing the cost of the presence cycle. This paper watched out for the creation of an "Creamer Energy Stockpiling Gadget for an Electric Vehicle Battery-Super capacitor" The goal of joining batteries and super capacitors is to develop an energy amassing contraption with the battery's high energy thickness and the super capacitor's incredible thickness. One of

the weights of the lithium molecule battery is that it isn't remarkable for the passing receptiveness of a huge load of force inferable from the deficiency of its conveyance limit. A rehashed charge-conveying improvement of the battery accomplishes a lessening in its association life. The super capacitor is along these lines used to help battery life. The capacity and execution of an Electric Vehicle (EV), perhaps the primary task is to work on the show and nature of the electrical energy putting away design like electrical force thickness and energy limit.

### Literature Review

Chotia et al. (2018)<sup>1</sup> The proposed development of active power and component electric vehicles actually accelerated the breaking point there. The smart limit considered hybridized for supercapacitor battery depends on this new development but your suitability is now explained. The structure of the mix battery supercapacitor limit is investigated and separated along with the ground-based battery collection structure. Gadgets were considered cost-effective, energy quality, complex course of action, direct component, turnaround events, test exhibition and estimated benefits. The survey shows that the various combinations provide basic strength and power in management reviews, future battery upgrades and hig Jianwei Li et al. (2017) have suggested that significant challenges to power systems are

driven by the need for energy and common concern, in order to make clear the inefficient entry into the ecosystem energy and eliminate unlimited energy consumption. By looking at the flexible concept of renewal, a power profile created will no doubt be able to edit with an important stack. Similarly, much is thought about the potential for energy conservation to ensure unlimited power corridors. Recently, the development of supercapacitor (SC) has made the SC and hybrid energy storing structure (HESS) really attractive. Divided power and other strength-enhancing advantages of SC-focused benefits are: unimaginable thickness, high bicycle life, and high altitude. current overseeing limits. In any case, SC is correspondingly weak in low energy thickness. The battery is portrayed by gigantic energy thickness yet low in power limit. In the microgrid structures, high-rehash power changes will cause an essential level of battery power cycling. This, thusly, has been displayed to incite a fundamental decrease in battery association life. Subsequently, the chance of the SC and battery mutt conspire is proposed. A setting focused assessment of the HESS subject to a microgrid is presented in this paper.

Jianwei Li et al. (2017)<sup>2</sup> have proposed that greater complexity in energy structures is driven by energy demand and general anxiety, unambiguous functioning of pure penetration into the biological system and working in the hands of high energy. Due to differences in what is thought to be renewable, the generated energy profile cannot be adjusted by the critical mass. In the same way, many theories have been based on the advancement of the power to slow down progress in order to ensure sustainable dynamics. More recently, advances in supercapacitor (SC) have made the SC and the battery and half of the power collection (HESS) facilities really shiny. Separated power collections and other moving averages for the benefits of SC are: incredible thickness, high bike life, and high-end current control limits. In any case, the SC is almost weak with a low power density. The battery is characterized by high power but low power consumption is limited. In microgrid structures, high-power transformations will create a basic level of battery power circulation. This, in turn, has been shown to significantly reduce battery life. Thus, it is proposed to capture the SC and battery mutt scheme. An intermediate setting test for fewer microgrids HESS is presented in this paper.

Lia Kouchachvili et al. (2018)<sup>3</sup> which tends to attract the opportunity of experts in charge of various aspects of the industry to focus unequivocally on the possibilities of connecting nearby battery / supercapacitor EV structures. Therefore, an important difference between the introduction of these electrochemical cells into the power source of the various EVs with conventional power combinations should be considered. Here, we have tried to provide a program for a possible exhibition of battery / supercapacitor structures on EVs. The rapid connection between the size and performance of the PC battery and the power source required in the EV indicates that new types of electrochemical cells are required for future EVs. However, a large fraction of the standard potential

of EV power sources is basically the long-term nature of standard, disposable battery structures.

A little. R. Rade (2018)<sup>4</sup> has shown the actual planning and evaluation of Energy Stockpiling and leaders are an important factor in Electric Vehicle (EV). It will lead to the accumulation of valuable energy at reduced cost, a longer lifespan and an increase in the distance of vehicles. The planning and evaluation statistics presented in this paper are based on the hypothetical hypothesis of the selected vehicle. This article additionally introduces the power board between two exciting energy-saving machines namely double-flow power using a converter (Crossover Energy Stockpiling), a single power-saving device that cannot fill every positive product name. A common goal of the Mixture Energy Stockpiling Framework and board power to assist EV with acceleration, to restore renewable dialing. in addition, reducing battery pressure by constantly recognizing battery performance as unstable as possible during a misalignment and integrating a Supercapacitor (Ultracapacitor) to provide faster power during autonomous travel and without gaining power during deceleration. The performance of the Energy Conservation Framework is partially analyzed by a pilot program. It is clear that after discharge the battery the computing battery is always recognized as unstable as possible during the acceleration i.e. the normal current is supplied to the battery and during the accelerated current acceleration is supplied to the supercapacitor.

Mid-Eum Choi et al. (2016)<sup>5</sup> introduced batteries are seen as one of the most important components in EV. However most of the power in the batteries is made in a reliable way, which can be damaged by zenith current or power accumulation. To overcome this, a battery / super-capacitor (SC) Cross assortment Energy Aggregating Framework (HESS) is proposed. An important issue related to HESS active EV is how to control the current stream to limit the value / doubt of the current live stream throughout the EV battery. There is no denying that future weight profiles can be used to manage current streams on EV. Regardless, it is difficult to obtain certain weight profiles when considering the extent to which car progress depends on different components, e.g., traffic congestion in the city or driver exposure. In this paper, we propose an improved performance model for the current critical HESS development in EV but the future weight profile is inaccurate. The age results indicate that the proposed system can reasonably maintain the current battery / difference in EV.

Fiorenti et al. (2013)<sup>6</sup> introduced a new event change function and HESS DM test support that includes the same PbA battery party and EDLC for automated applications. Your DM for both PbA battery and EDLC is accepted with a comparable power circuit based system. Key testing was appropriate for outstanding evidence purposes. The terminal points of the PbA battery model are recognized as part of the SOC and the current value, while the terminal points of the EDLC model are perceived at different temperatures. The HESS model was then

joined to a car model to study the effect of battery integration on a car's mile and support battery pressure. They repeatedly looked like PbA and SC related to the inactive HESS system in the vehicle testing facility and tested their function under four conditions: free battery development, HESS, with start-up and stop upgrades and without continuous stopping. The first requested battery circuit model and subsequent interest model for EDLC were chosen as a retrospective between multi-layered environment (from both specific assumptions and entertainment point of view) and accuracy at all times on a reasonable scale. With a battery, the visual testing of the beat of the beat Ch / Dch (100% –65% SOC and 65% –100% SOC) is beyond what many would think could be done at 25 ° C. In the SC test, the Ch / Dch was made at three different temperatures (-18, 25, and 50 ° C) making an error in the SC current constant of 100 A to 2.7 V and transmitting at 100 values A current scale. 1.35 V voltage.

Théophile Pau et al. (2020)<sup>7</sup> Proposed electric vehicles are one of the key focus areas of today's new turmoil, called Industry 4.0. Vehicles and important systems associated with E flexibility, for example, in terms of equipment, are extended to modern offices. Therefore, electric forklifts are commonly used when it is assumed that nothing of the ozone layer is released during operation. In any case, they are often fitted with lead-damaging batteries that display horrible displays and prolonged charging time. Therefore, combining high-capacity lithium-molecule batteries with high-power supercapacitors as a hybrid energy storage system achieves the right indicators and creates the future of the battery. The proposed game plan is suitable for forklifts that start indefinitely, stop, lift and lose large weights. This paper introduces the battery ratio of a lithium-molecule / supercapacitor cream energy massing for a forklift vehicle, using the standard variable drive (VDI) driving cycle. To test the display of the lithium-molecule / supercapacitor cream storage system, an undeniable measurement has been completed. The fixed course of action allows us to optimize the structure such as power, volume and weight, in terms of battery, supercapacitor development and power board strategy taken.

Tingyou Ming et al. (2014)<sup>8</sup> familiar with work on the introduction of electric vehicle (EV), supercapacitor has been utilized as a partner energy storing up framework for battery because of its astonishing thickness and quick charging and conveying attributes. In any case, the test is the best way to deal with facilitates or smooth out these two energy resources to use their attributes automatically. In this paper, the power of the two layers of the board approach is proposed, apparently, the power layer and the power layer. From the power layer, a good charging condition (SOC) has not yet been selected to meet the power needs of the electric car, while the power separation has not been permanently stabilized between the battery and the supercapacitor from the power base. The cream-powered compound structure with both battery and supercapacitor is shown with Advocate and simulation results show that under different driving cycles the proposed process is relaxed and mind-boggling.

Y. Baghzouz (2013)<sup>9</sup> demonstrated the use of a supercapacitor bank when used as a power base to smooth off power outages with an electric car battery or cream. The survey looks at the critical situation in which the supercapacitor bank is clearly connected to the shunt and battery in the same way as the situation where it is connected to a critical DC / DC converter to achieve optimal performance. The work is done by automatic mixing during vehicle acceleration and descent. The initial data that is part of the model circuit is displayed accordingly. The proper layout of the electric power storage structure depends on it to bring amazing benefits to the success of the battery bank.

Z. Song et al. (2014)<sup>10</sup> suggested a sharp HESS suggestion using a moderator with minimal measurements between a slightly special HESS. The legal complaint was to shut down parts of the SC-battery structure in order to reduce its cost and to limit battery losses in view of its warm pollution. The adequacy of this HESS game program has been revised based on its regular China City Transport Driving Cycle (CBDC) exhibition. In the main function, the introduced game system uses a small DC / DC-C to register the battery power supply which will ensure that the SC power output is higher than the batteries of the driving conditions in the city. In the current state the battery may overheat when the SC voltage falls below the battery capacity. In line with these lines, the solid weight profile is designed for battery. Otherwise, the battery is not used to receive power directly from the RB; in these lines, the battery is not affected by current spikes and the battery presence is extended. The entertainment results showed an abundance of the proposed HESS set with a LiFePO<sub>4</sub> and SC battery. This HESS had high electricity, surprisingly high limit and long cycle life in relation to NiMe-H, Nickel-Collection, and PbA; however it did not perform better at lower temperatures. Two driving and downgrading modes were considered where the potential results were split into USC > Bat or USC ≤ Bat. In the event that the SC is not fully charged all the RE will be dealt with in the SC, and in the full renewal, at that time, all the RE will be dealt with in the battery. By USC > Bat, the power is fully supplied by the SC to the electric motor (stored in the battery power distribution via the diode), while due to the USC ≤ Bat, the battery and SC are directly aligned through the circuit-related diode and moreover both hold the power of an electric engine. After some time, an unconventional system (DP) approach was introduced to this program. The results from this review are astounding in the extended steps of SCs in HESS. Tailors have proposed a simplification of battery size and SC package package in HESS based on requirements relating to non-critical distance to city travel.

**Proposed System:** A Crossbreed Energy Storing Structure (HESS) battery-super condenser is proposed for electric drive vehicles including electric, cross assortment electric and module crossover electric vehicles. Curiously, with the standard HESS plan, which utilizes a more prominent DC-DC converter to interface between the super capacitor and the battery-dc relationship with satisfy constant pinnacle power needs, the

course of action utilizes substantially more unassuming DC-DC converter that limits as a controlled energy manual for stay mindful of super capacitor voltage at a worth higher than the battery voltage for most metropolitan driving conditions The framework possibly supplies power straightforwardly if the voltage of the super capacitor diminishes under the voltage of the heap. Along these lines, a decently unsurprising weight profile for the battery is made. In like manner, the battery isn't utilized to collect energy obviously from the regenerative toning down; all things considered, the player y is disconnected from ordinary charges, which will build the battery life. To check the proposed framework are introduced redirection and fundamental results. Another battery super condenser Hybrid Energy Accumulating System is being proposed in this theory to address the issue. The batteries are relied upon to stay away from unequivocal cutoff points for auto applications, for example, instatement, speeding up, toning down and energy recuperation.

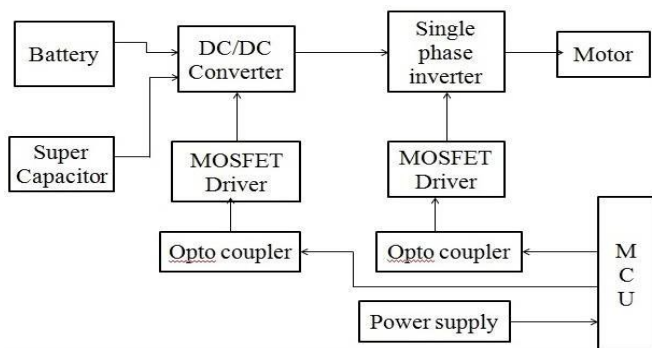

**Figure-1:** Hybrid energy storage system for electric vehicle<sup>2</sup>.

These objectives give us an unbelievably liberal high energy battery showed up diversely according to the one needed for these applications. From now on, decay the significance of the breaking point structure; the battery can be facilitated with high force modules like super capacitor. It is one of the basic difficulties in expanding both the electric vehicle's productivity and execution to the degree electric force thickness and energy limit. Super condenser joins framework utilizing a static force converter. These frameworks can be absolutely electrical or with Force module. The MATLAB reenactment is done to assess the convenience and to look at the decay of battery strain. Reenactment model of crossover energy source is familiar and used with examine the course of action progress of electric vehicle on board of fuel source like energy handiness and breaking point mass. Show of super capacitor diminishes electric loads, builds helpfulness and deals with the general show. The microcontroller produces a genuine heartbeat (0,1) through an optocoupler. Optocoupler is only that the posted notice of one circuit can be constrained by another data signal in another circuit. The standard guard behind utilizing the Optocoupler is the unit of the two circuits and the thriving of the contraption against switch current. The optocoupler yield is given to a MOSFET driver which goes most likely as an

exchanging gadget, subject to the responsibility of the optocoupler. Battery provides DC-DC Converter with an obvious voltage of 12V. DC-DC Converter is just a lift converter used to raise the voltage from around (90V to 120V). In like manner, the Super Capacitor gives DC-DC Converter one more data Battery DC-DC Converter with a clear voltage of 12V. DC-DC Converter is just a lift converter used to raise the voltage from around (90V to 120V). In like manner, the Super Capacitor gives DC-DC Converter another information. The converter yield is given to a solitary stage inverter that changes DC relationship over to AC yield. Motor requires a climate control system obligation to utilize the single stage inverter. The principal engine is a climate control system affirmation engine, it is a forced air system electric engine that works the electrical stream required in the rotor to give the force and drive. Utilizing the super condenser will reach out generally speaking execution and efficiency.

## Conclusion

Both common problems and market demand have led to the recommendation of EVs, this time electrochemical energy storage systems that are far behind in speculation to match fuel-based vehicles. But the latest advances in battery propellers have provided excellent opportunities to transmit EVs, which can combat clock viewing, which is important in both thermodynamics and battery-based electrochemical reactions that do not fully meet the essentials of flawless power. use of vehicles. For this, using an SC near the battery structure may satisfy the need. In this hybrid setting, SC can quickly (short time, a few seconds), provide power when the battery structure fails to perform properly. From now and in the foreseeable future, a steady supply of power is provided by the battery pack. In any case, the battery / SC system is not as important as connecting the two power sources. In any cell plans alone, the entire electrical structure must be carefully planned to collect the numerical power source. Decide when and how each electrochemical cell should be charged or delivered. This is joined by a sophisticated, pleasurable method of application associated with routine electrochemical cell testing. Thus, future cell planning should be established through a joint closure between experts working on electrochemistry a piece of energy source and the people who plan the electrical system for every energy source in EV. A large number of integrated frameworks followed by EVs rely on commercial batteries and SCs, which have not been developed since now. All in all, arrange batteries and SCs under the mutt power system requirements for EVs. An important dimension of this point is found in the openness of the two-battery storage devices and SCs, which may not be useful in known systems, but offer new opportunities in EV systems.

## Acknowledgement

I give my sincere gratitude to my guides Mr. Mousam Sharmasir and Mr. Mukesh Ku Chandrakar sir for helping me in accomplishing my work.

## References

1. Chotia, I. and Chowdhury S. (2018). Battery Storage and Hybrid Battery Supercapacitor Storage Systems: A Comparative Critical Review. *IEEE Energy Conversation Conference*.
2. Jianwei Li, Bertrand Cornelusse and Philippe Vanderbemden (2017). A SC/battery Hybrid Energy Storage System in the Microgrid. *Energy Procedia*, 142, 3697–3702, Elsevier.
3. Lia Kouchachvili, Wahiba Yaïci and Evgueny Entchev (2018). Hybrid Battery/Supercapacitor Energy Storage System for the Electric Vehicles. *Journal of Power Sources*, 374, 237–24, Elsevier.
4. Minal. R. Rade (2018). Design and Development of Hybrid Energy Storage System for Electric Vehicle. *International Conference on Information, Communication, Engineering and Technology*, 978-1-5386-5510-8/18/\$ 31.00 ©2018 IEEE.
5. Mid-Eum Choi and Seung-Woo Seo (2016). Robust Energy Management of a Battery / Supercapacitor Hybrid Energy Storage System in an Electric Vehicle. *IEEE Transaction Smart Grid*.
6. Fiorenti S., Guanetti J., Guezennec Y. and Onori S. (2013). Modeling and Experimental Validation of a Hybridized Energy Storage System for Automotive Applications. *J. Power Sources*, 241, 112–120, <http://dx.doi.org/10.1016/j.jpowsour.2013.04.017>.
7. Théophile Paul, Tedjani Mesbahi, Sylvain Durand, Damien Flieller and Wilfried Uhring (2020). Sizing of Lithium-Ion Battery/Supercapacitor Hybrid Energy Storage System for Forklift Vehicle. *Energies*.
8. Tingyou Ming, Weiwen Deng, Jian Wu and Qiao Zhang (2014). A Hierarchical Energy Management Strategy for Battery-Supercapacitor Hybrid Energy Storage System of Electric Vehicle. *ITEC Asia-Pacific*, 1569952025.
9. Pay, S., & Baghzouz, Y. (2003). Effectiveness of battery-supercapacitor combination in electric vehicles. In 2003 IEEE Bologna Power Tech Conference Proceedings, 3, 6. IEEE.
10. Z. Song, J. Li, X. Han, L. Xu, L. Lu and M. Ouyang (2014). Heath Hofmann Multi-Objective Optimization of a Semi-Active Battery/Supercapacitor Energy Storage System for Electricvehicles. *Applied Energy*, 135, 212–224. <http://dx.doi.org/10.1016/j.apenergy.2014.06.087>.